



The CLEO Effect lamps are the first in a new, tanning lamp, generation.
 In contrast with the other CLEO lamps, the CLEO Effect lamp has a T8 diameter. The lamp is emitting long wave UV radiation between 300 - 400 nm.
 The UV-B/UV-A ratio is 1.0 % (UV-B: 280-315 nm) or 2.0 % (UV-B: 280 - 320 nm).
 The benefit of this lamp is that the erythemal radiation below and above 320 nm is equal.
 Within the boundaries described in IEC 335-2-27, the maximal irradiance level can be created with the use of this lamp.

Warning

UV radiation, like solar radiation, can cause eye and skin injury if the appropriate safety measures are not observed. Always follow the manufacturer's instructions carefully when using any tanning product or system.
 When replacing tanning lamps in existing equipment, always adjust the tanning times according to the equipment manufacturer's instructions for the new lamp type.

Applications

Indoor tanning.

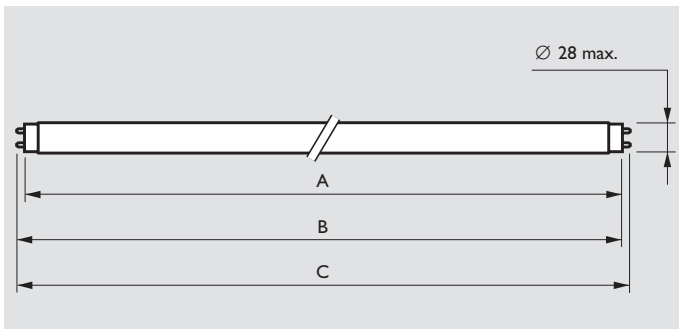

Dimensions in mm

Type	A max.	B min.	B max.	C max.
CLEO EFFECT 70W (-R)	1500.0	1504.7	1507.1	1514.2
CLEO EFFECT 90W (-R)	1763.8	1768.5	1770.9	1778.0

Type	Cap/ base	Lamp voltage V	Lamp current A	UV-A radiation W	Erythemal radiation ≤ 320 nm mW	Erythemal radiation > 320 nm mW	Depreciation at 500 hrs %	Nett weight g	Ordering number
EFFECT									
CLEO EFFECT 70W	G13	105	0.85	18	14	14	15	233	9279 450 00900
CLEO EFFECT 70W -R	G13	105	0.85	16	12	12	20	233	9279 451 00900
CLEO EFFECT 90W	G13	114	1.0	23	17	17	15	272	9279 455 00900
CLEO EFFECT 90W -R	G13	114	1.0	21	15	15	20	272	9279 456 00900

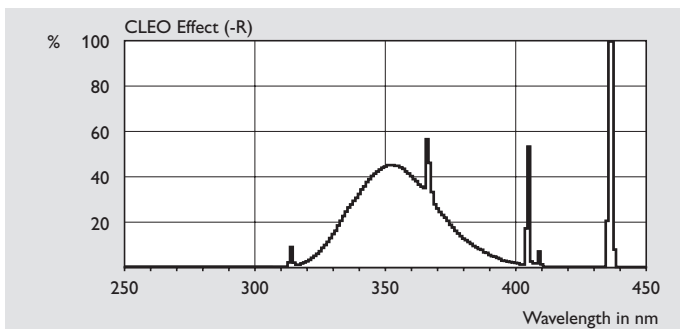

Spectral power distribution

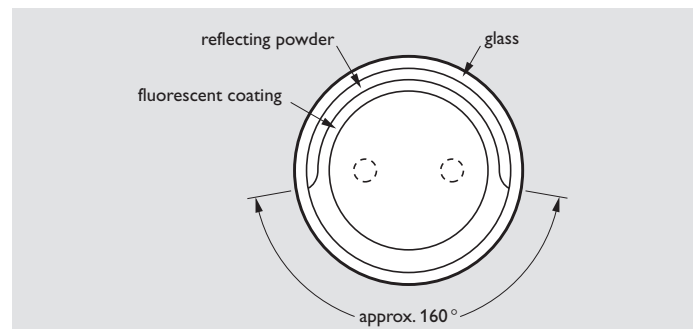

Cross-section -R version

